



**Linee Automatiche
di Frittura e
Bollitura**
dal 1981

più di 30 anni d'esperienza



AUTOMATIC DOSER WITH ONE OR TWO HEAD



FEATURES:

- Doser for pancakes and donuts that directly discharges on the fryer;
- Various shapes and dimensions of extrusion, depending on mold installed;
- Amount of variable dose;
- Adjustable dosing height;
- Continuous dosing over the entire width of the fryer;
- Adjustment of the lateral displacement speed to determine the distance between one dose and another;
- Quick return without dosing;
- Variable pause time after return;
- Possibility to adjust the lateral movement;
- Structure mounted on wheels, two fixed and two swivel with brake;
- Large compartment with closing door;
- Removable parts for possible remote maintenance;
- Easy cleaning.

TECHNICAL FEATURES:

- Overall dimensions cm 61x82x160;
- Hopper capacity with one head:≈ 10 Liters;
- Hopper capacity with two head:≈ 20 Liters;
- Control panel on the machine;
- Large compartment with closing door, to store items;
- Removable parts for cleaning;
- Structure and parts constructed integrally with materials suitable for contact with food;
- Maximum electric power used 250W;
- CE marking.

TYPES OF STAMPS:



DIMENSIONS:

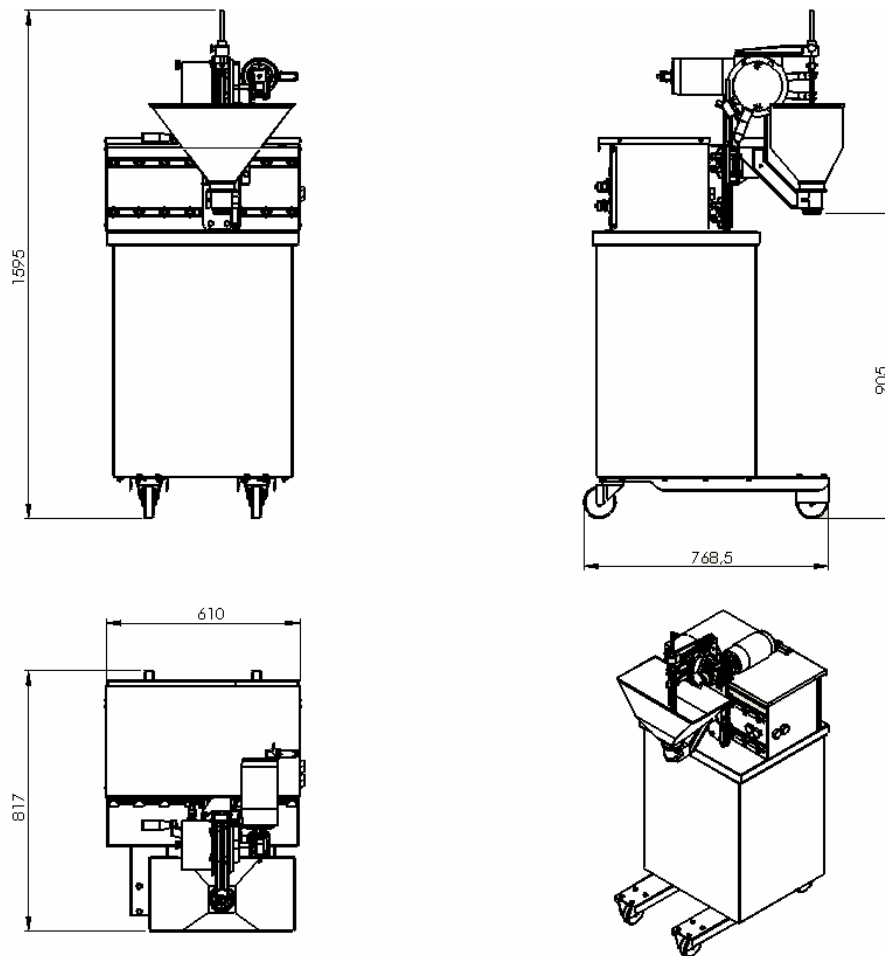

Indicative hourly production:

The hourly production varies depending on the type of extrusion used and the number of extruders per head, for precise indications about the hourly production we invite you to make a specific request